

(EN): Before first use:

1. Pull out insulation tag as (Fig 1)
2. Press on roof for lights and sounds. (Fig 2)

(FR): Lors du premier usage:

1. Retirez la languette comme dans la (Fig 1)
2. Appuyez sur le toit pour sons et lumières. (Fig 2)

(DE): Vor dem ersten Spielen:

1. Isolierstreifen wie in Abb. (Fig 1)
2. Drücken Sie auf dem Dach für Lichter und Klänge. (Fig 2)

(ES): Jugando por primera vez:

1. Retira el marbete aislante como en la (Fig. 1)
2. Presionar en el techo de luces y sonidos. (Fig 2)

(IT): Giocando per la prima volta:

1. Estrai il cartellino di isolamento come nella (Fig 1)
2. Premere sul tetto per luci e suoni. (Fig 2)

(Fig 2)

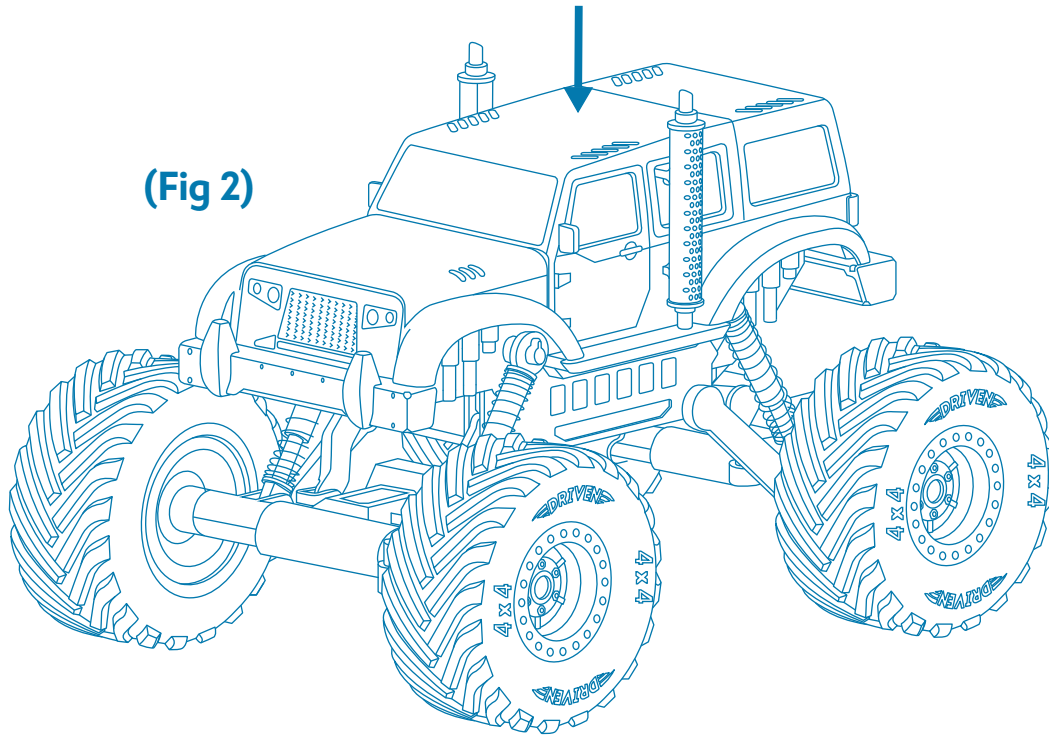

REPLACING BATTERIES / REMPLACEMENT DE PILES BATTERIEN AUSWECHSELN / CAMBIO DE PILAS / SOSTITUZIONE BATTERIE

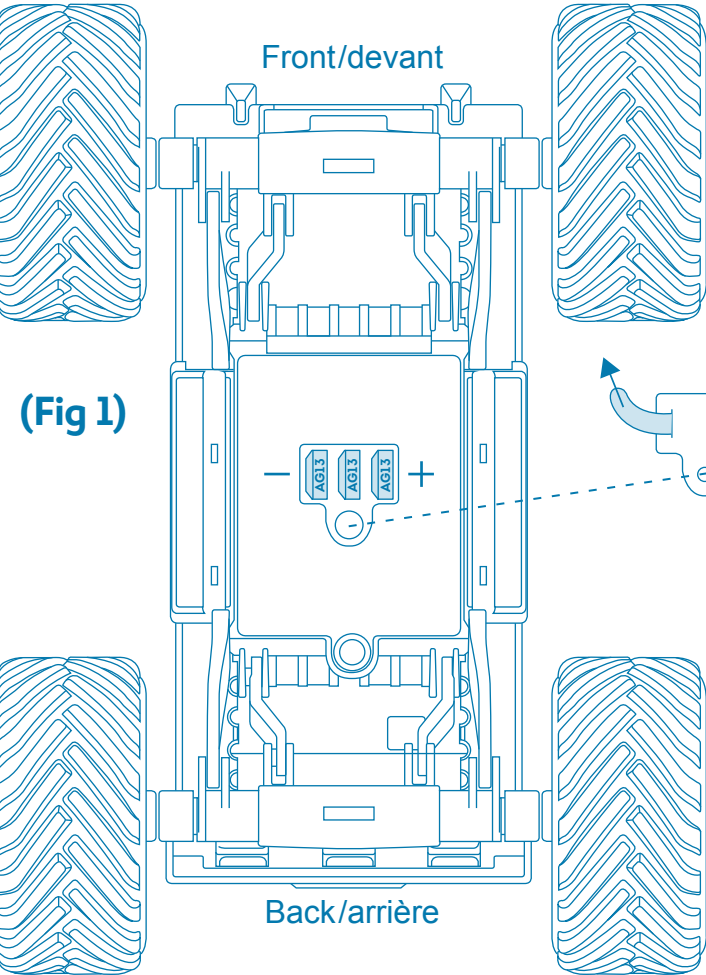

(Fig 1)

Close
En arrêt
Schließen
Cerrado
Spento

Open
En marche
Öffnen
Encendido
Accesso



(EN): WARNING: SMALL PARTS - CHOKING HAZARD. Not suitable for children under 3 years.
(FR): ATTENTION: PETITS ÉLÉMENTS - DANGER D'ÉTOUFFEMENT. Ne convient pas aux enfants de moins de 3 ans.
(DE): ACHTUNG! KLEINE TEILE - ERSTICKUNGSGEFAHR. Nicht für Kinder unter 3 Jahren geeignet.
(ES): ¡ADVERTENCIA! PIEZAS PEQUEÑAS - PELIGRO DE ATRAGANTAMIENTO. No apropiado para niños menores de 3 años.
(IT): AVVERTENZA! RISCHIO DI SOFFOCAMENTO DI PICCOLE PARTI. Non adatto a bambini di età inferiore a 3 anni.
(NL): WAARSCHUWING! KLEINE ONDERDELEN - VERSTIKKINGSGEVAAR. Niet geschikt voor kinderen jonger dan 3 jaar.
(DK): ADVARSEL: SMÅ DELE - FARE FOR AFKØRNING. Ikke egnet til børn under 3 år.
(SE): VARNING: KVÄVNINGSRISIK - Små delar. Inte för barn under 3 år.
(PL): OSTRZEŻENIE! MAŁE ELEMENTY - NIEBEZPIECZENSTWO ZADŁAWIENIA. Nieodpowiednie dla dzieci w wieku poniżej 3 lat.
(GR): ΠΡΟΣΟΧΗ! ΚΙΝΔΥΝΟΣ ΠΝΙΓΜΟΥ - Περιέχονται Μικρά Μέλη. Δεν είναι κατάλληλο για παιδιά ηλικίας κάτω των 3 ετών
(AR): تحذير: خطر الاختناق لأن المنتج يحتوي على أجزاء صغيرة لا تناسب الأطفال دون 3 سنوات



⚠ WARNING: This product contains Button or Coin Cell Battery. A swallowed Button or Coin Cell Battery can cause internal chemical burns leading to death in as little as two hours. Dispose of used batteries immediately. Keep new and used batteries away from children. If you think batteries might have been swallowed or placed inside any part of the body, seek immediate medical attention.

⚠ WARNING:
CHOKING HAZARD—Small parts.
Not for children under 3 years.

⚠ WARNING:
Contains Button or Coin Cell Battery.
Hazardous if swallowed—see instructions.

⚠ AVERTISSEMENT:
RISQUE DE SUFFOCATION—Petites pièces.
Ce produit n'est pas recommandé pour les enfants de 3 ans et moins.

⚠ AVERTISSEMENT:
Contient une pile bouton. Dangereux en cas d'ingestion—voir les instructions.

